

## Operating Instructions

SC02.2040

1:4 HDMI Splitter, 4K@60Hz, HDMI 2.0, HDCP 2.2, HDR



### Notice

The information in this document is subject to change without notice. Every effort has been made in the preparation of this document to ensure accuracy of the contents, but all statements, information, and recommendations in this document do not constitute the warranty of any kind, express or implied.

### Features

- Simultaneously display a single UHD 4K source on 4 x displays
- Supports resolutions up to 4Kx2K (3840 x 2160@60Hz, YUV 4:4:4) 3D
- Compliant with HDMI 2.0, HDCP 2.2, HDR10
- Supports 36-bit Deep Colour
- Supports LPCM 7.1, Dolby® TrueHD, Dolby Digital® Plus and DTS HD® Master Audio™
- Bandwidth: 18Gbps

### Package Contents

- 1 x HDMI Splitter
- 1 x 5V/1A DC Adapter
- 1 x User Manual

## Specifications

Supported Resolutions	<ul style="list-style-type: none"> <li>▪ 480i@60Hz, 480p@60Hz, 576i@50Hz, 576p@50Hz, 720p@50/60Hz, 1080i@50/60Hz, 1080p@50/60Hz, 4Kx2K @24/25/30/60Hz</li> </ul>
HDMI Signal	<ul style="list-style-type: none"> <li>▪ HDMI 2.0 and HDCP 2.2, YUV 4:4:4, HDR10</li> </ul>
Audio	<ul style="list-style-type: none"> <li>▪ LPCM 7.1, Dolby Digital™ and DTS Digital Surround™</li> </ul>
Power	<ul style="list-style-type: none"> <li>▪ DC5V/3A</li> </ul>
Power Consumption	<ul style="list-style-type: none"> <li>▪ 1W Maximum</li> </ul>
Mean Time Between Failure (MTBF)	<ul style="list-style-type: none"> <li>▪ &gt;30000 Hours</li> </ul>
Working Temperature	<ul style="list-style-type: none"> <li>▪ 5 ~ 35°C</li> </ul>
Humidity	<ul style="list-style-type: none"> <li>▪ 0 ~ 90% (no condensation)</li> </ul>
Dimensions	<ul style="list-style-type: none"> <li>▪ 150(W) x 63(D) x 17(H)mm</li> </ul>
Weight	<ul style="list-style-type: none"> <li>▪ 245g</li> </ul>

## Panel Description

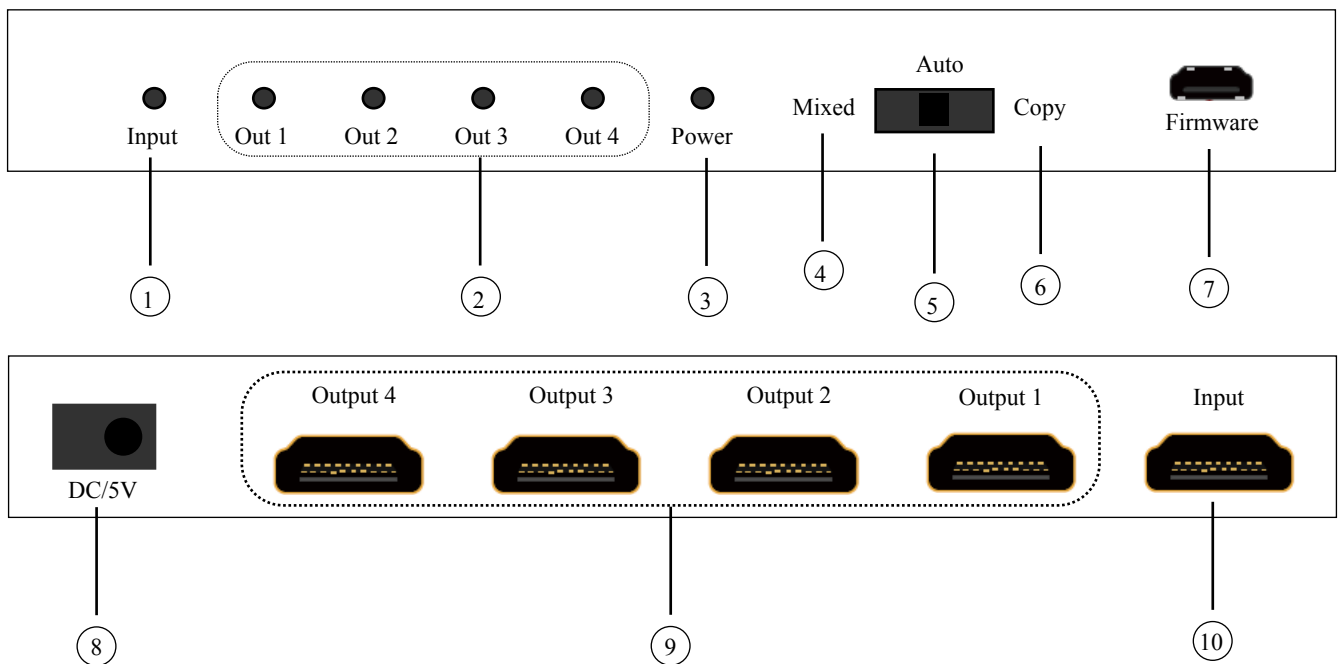

- |                           |                         |
|---------------------------|-------------------------|
| 1. Input LED              | 6. Switch to Copy EDID" |
| 2. Output LED's           | 7. Firmware Port        |
| 3. Power LED              | 8. Power Input          |
| 4. Switch to "Mixed EDID" | 9. HDMI Outputs         |
| 5. Switch to "Auto EDID"  | 10. HDMI Input          |

## EDID Settings

Copy EDID: Output 4 is the priority port

When a display is connected to output 4, the splitter will set output 1/2/3 with the same resolution as output 4.

Auto: Default EDID setting 4K@60Hz

Mixed EDID: The resolution will be set to the lowest resolution screen connected to the splitter. This will ensure all displays function correctly.

Note: The HDCP version takes priority over EDID settings when in mixed mode. If the source is HDCP 2.2 the splitter will output 4K@60Hz, if any TV doesn't support HDCP 2.2 it will output 1080p. See the table below.

Input Source	HDMI Display Supporting HDCP 2.2	HDMI Display that doesn't support HDCP 2.2
HDCP 2.2 4K@60Hz	HDCP 2.2 4K@60Hz	HDCP 1.4 1080p@60Hz
HDCP 2.2 4K@24Hz	HDCP 2.2 4K@24Hz	HDCP 1.4 1080p@24Hz
HDCP 1.4 4K@24Hz	HDCP 1.4 4K@24Hz	HDCP 1.4 4K@24Hz

Note: HDR is supported in Copy and Mixed EDID modes.

## Connecting and Operating

- 1) Connect the HDMI input source to the input port of the splitter.
- 2) Connect the splitters HDMI output ports to the displays.
- 3) Power the splitter, source and displays.

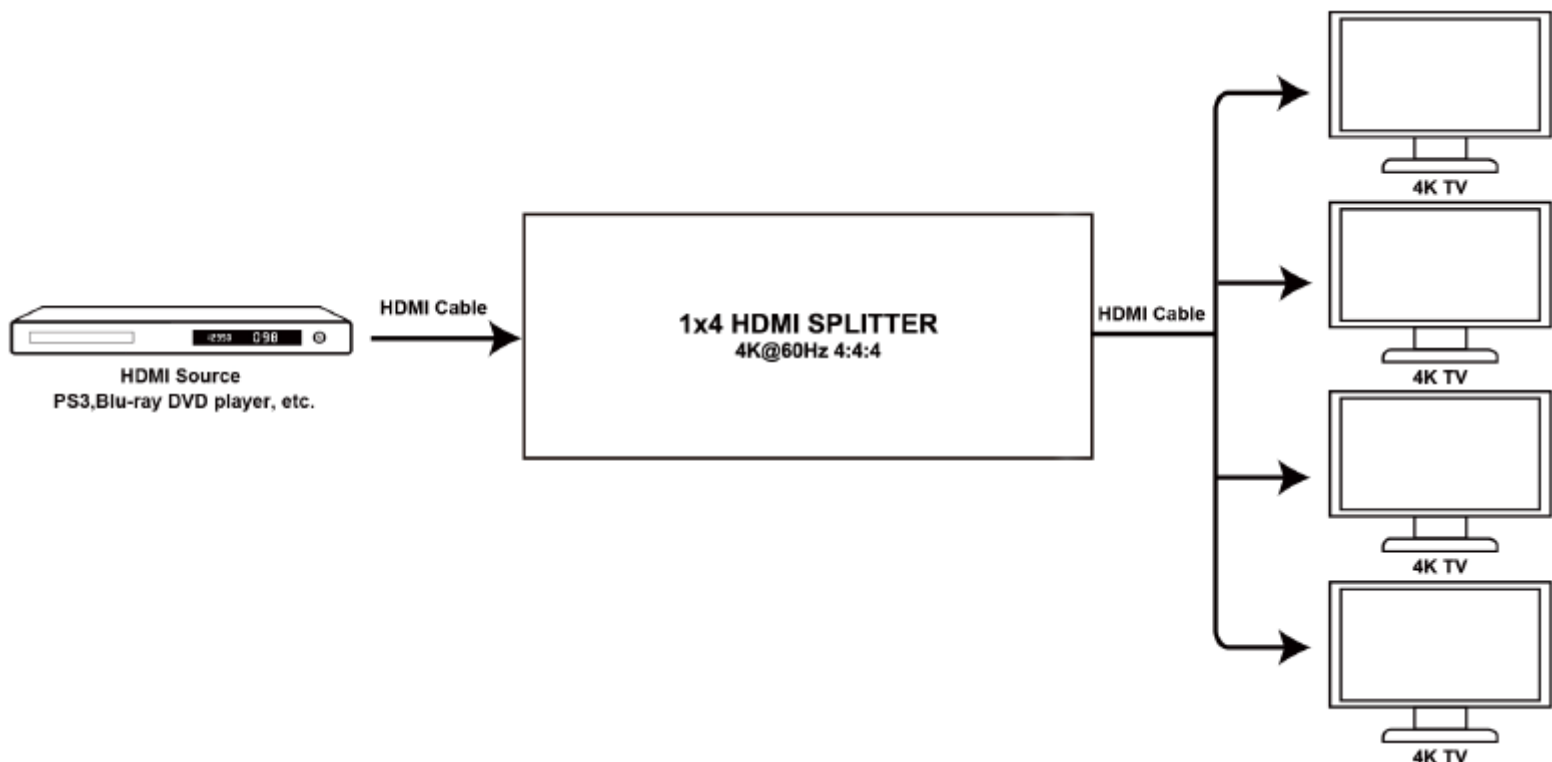

## Safety Information

### Product Servicing

**1. Damage requiring service:** The unit should be serviced by qualified service personnel if:

- [a] The DC power supply cord or AC adapter has been damaged
- [b] Objects or liquids have entered the unit.
- [c] The unit has been exposed to rain.
- [d] The unit does not operate normally or exhibits a marked change in performance.
- [e] The unit has been dropped or is visibly damaged.

**Servicing personnel:** Do not attempt to service the unit beyond that described in these operating instructions. Refer all other services to authorised servicing personnel.

**2) Replacement parts:** Should parts need replacing, ensure the servicer uses parts specified by the manufacturer or parts that have the same characteristics as the original parts. Unauthorised substitutes may result in fire, electric shock or other hazards.

**3) Safety check:** After repairs or service, ask the servicer to perform safety checks to confirm that the unit is in proper working condition.

### Warranty

If your product does not work properly because of a defect in materials or workmanship, our company (referred to as “the warrantor”) will, for the length of the period indicated below, (Parts (2) years, Labour (90) Days) which starts with the date of original purchase. (“Limited Warranty Period”), at its option either [a] repair your product with new or refurbished parts, or [b] replace it with a new or refurbished product. The decision to repair or replace will be made by the warrantor. During the “Labour” Limited Warranty period there will be no charge for labour. During the “Parts” warranty period, there will be no charge for parts. You are expected to return the product during the warranty period. This Limited Warranty is extended only to the original purchaser and only covers product purchases as new. A purchase receipt or other proof of purchase date is required for Limited Warranty service.

#### Returning the product

When returning the product during its warranty period, please ensure to use adequate packing to protect the unit in transit, preferably the original packaging and ensure the unit is insured during the process. Include a letter detailing the failure and provide an daytime telephone number or email address where we can contact you.

#### Limited Warranty Limits and Exclusions

1] The Limited Warranty only covers failures due to defects in materials or workmanship and does not cover normal wear and tear or cosmetic damages which occurred in shipment, or failures which are caused by products not supplied by the warrantor, or failures that result from accidents, misuse, neglect, mishandling, misapplication, alteration, faulty installation, set-up adjustments, misadjustment of consumer controls, improper maintenance, power line surges, lightning damage, modification or service carried out by anyone other than a Factory Service centre or other authorised service, or damage that is attributable to acts of god.

2] There are no express warranties except as listed under “Limited Warranty Coverage”. The warrantor is not liable for incidental or consequential damages resulting from the use of the product, or arising out of any breach of the warranty. For example: this includes damages for lost time, cost of removing or re-installing the unit, travel to and from the service, loss of or damage to media or images, data or recorded content. The items listed are not exclusive, but are for illustration only.

3] Parts and service, which are not covered by this limited warranty are your responsibility.